

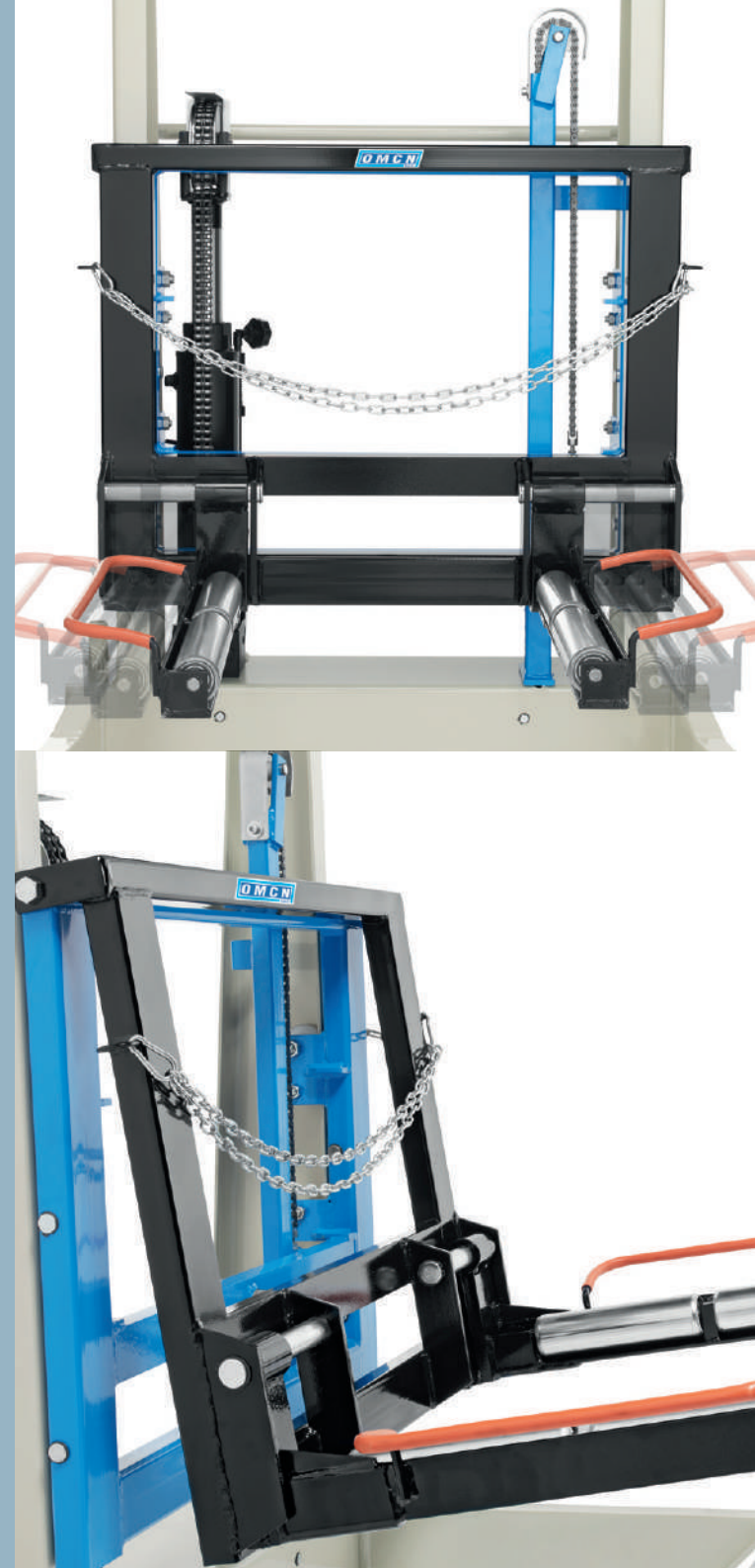

ART. 227/A



## ART. 227/A

Apparecchio a funzionamento idraulico per operare su pesanti automezzi per lo smontaggio e montaggio di ruote semplici e gemellari, con comando sia a mano che a pedale. Completo di 4 ruote girevoli e doppi rulli a cuscinetti sui bracci di sollevamento. **Bracci regolabili in senso trasversale e reclinabili onde facilitare l'operazione di centratura dei fori.**

Hydraulic functioning apparatus which operates on heavy vehicles to disassemble simple and twin wheels. It has a hand and foot-lever control. It is equipped with 4 turning wheels and double rolls with bearings on hoisting arms. **The arms are adjustable in transversal directions and reclining, in order to make the hole centering easier.**

Elévateur hydraulique à monter et démonter les roues simples ou jumelées des poids lourds, avec commande manuelle et à pédale. Equipé de 4 roues pivotantes et de double rouleaux sur les bras de levage.

**Bras réglables dans le sens transversal et inclinables, afin de faciliter le centrage des trous des jantes.**

Hydraulik-Gerät für die Arbeit an schweren Fahrzeugen. Geeignet zur Demontage und Montage einzelner Reifen sowie Zwillingsreifen. Sowohl Hand-als auch Pedalbedienung. Ausgestattet mit lenkbaren Rädern und Tragarmen mit doppelten, kugelgelagerten Rollen.

**Zusätzliches Neigen des Lifts möglich, um das genaue Zentrieren des Rades zu erleichtern.**

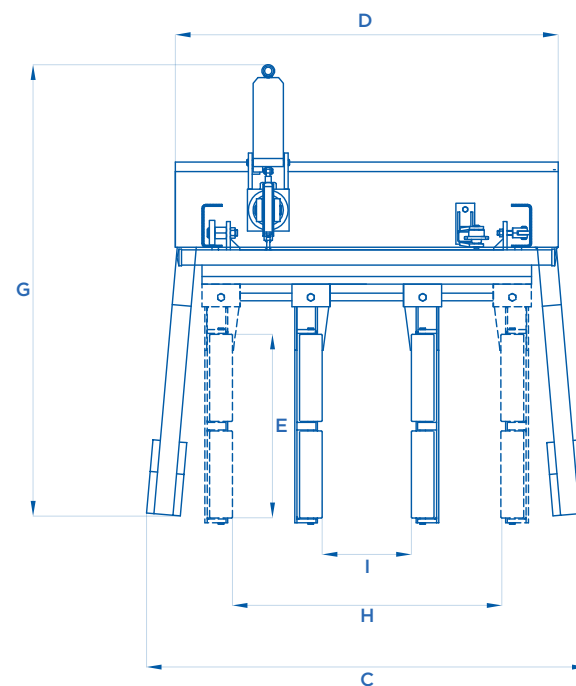
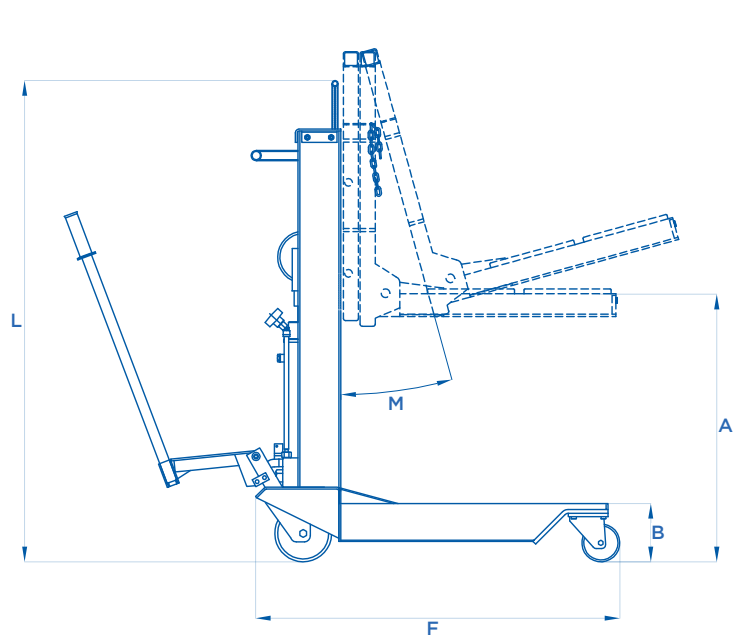

ART.		A mm	B mm	C mm	D mm	E mm	F mm	G mm	H mm	I mm	L mm	M $\alpha$
227/A	700 kg	650	160	1150	1000	490	920	1150	740	470	1410	10°